

PUERTAS SEMIAISLADAS SEMI-INSULATED DOORS PORTES SEMI-ISOLÉES

SERVICIO
SERVICE
SERVICE

MOD **N40**
SOBRE MARCO
ON FRAME
SUR CADRE



Puerta semiaislada destinada a locales de temperatura positiva, oficinas, salas de trabajo, laboratorios... Un diseño simple, sanitario y efectivo.

Semi-insulated door designed for premises with positive temperature, such as offices, workrooms, laboratories, etc. A simple, sanitary and effective design.

Porte semi-isolée destinée à dux locaux à température positive, bureaux, salles de travail, laboratoires... Une conception simple, sanitaire et efficace.

HOJA / LEAVE / VANTAIL

CONSTRUCCIÓN / CONSTRUCTION / CONSTRUCTION
Fabricada con un bastidor de perfil estructural de aluminio anodizado.

Made with an anodised aluminium structural profile frame.

Fabriqu  avec un b ti de profil  structurel en aluminium anodis .

REVESTIMIENTO / COATING / REV TEMENT
Chapa de acero galvanizado y lacado con pintura de poli ster de 25  m. Color blanco. Recubierto de un film protector pelable. Calidad alimentaria.

Galvanised steel sheet coated with 25  m polyester paint. White in colour. Covered by a peelable protective film. Food grade.

T le en acier galvanis  et laqu  avec de la peinture polyester de 25  m. Couleur blanche. Recouvert d'un film protecteur d tachable. Qualit  alimentaire.

AISLAMIENTO / INSULATION / ISOLATION
Espuma de poliisocianurato (PIR) inyectado a alta presi n de densidad 40-43 Kg/m .

High-pressure injected polyisocyanurate (PIR) foam with a density of 40-43 kg/m .

Mousse en polyisocyanurate (PIR) inject    haute pression densit  40-43 kg/m .

ESPESOR / THICKNESS /  PAISSEUR
40 mm.

HERRAJES / FITTINGS / QUINCAILLERIE

Cerradura, bisagras y manilla inoxidable.

Stainless steel lock, hinges and handle.

Serrure, charni res et poign e en acier inoxydable.

MARCO / FRAME / CADRE

Hoja montada sobre un marco para su posterior acoplamiento a panel. Construido con perfiles de aluminio lacados. Dotado de un burlete en todo el per metro de cierre.

Door leaf assembled on a frame and ready to be installed on panel. Built with aluminium profiles. Provided with a weather strip on the entire perimeter closing edge.

Vantail mont  sur cadre pour  tre fix  au panneau. Fabriqu  avec des profil  en aluminium laqu .  quip  de'un joint sur tout le perime de fermeture.

OPCIONES / OPTIONS / OPTIONS

Otros acabados del revestimiento.
Marco preparado para obra civil.
Tope puerta.
Cierra-puertas.
Cerradura con llave.
Cerradura con condensa.
Cierre el ctrico.
Mirilla de metacrilato 350 x 600.
Antip nico.
Antip nico alto m ximo 2.500 mm.
Protecci n bajo puerta de altura 850 mm.
Paso de rail a reo.

Other coating finishes.
Frame prepared to assembly on brickwall.
Door stopper.
Door closer.
Lock with key.
Lock with latch.
Electric lock.
Methacrylate window 350 x 60
Anti-panic bar.
Anti-panic bar in doors with max 2.500 mm height.
850 mm high kickplate.
Overhead rail passage.

Autres finitions de rev tement.
Cadre pr par  pour les travaux de g nie civil.
But e port.
Ferme-portes.
Serrure avec cl .
Serrure avec verr.
Fermeture  lectrique.
Judas en m thacrylate 350 x 600.
Anti-panique.
Anti-panique hauteur maximale 2 500 mm.
Protection sous porte hauteur 850 mm.
Passage de rail a r

HOJA SIMPLE

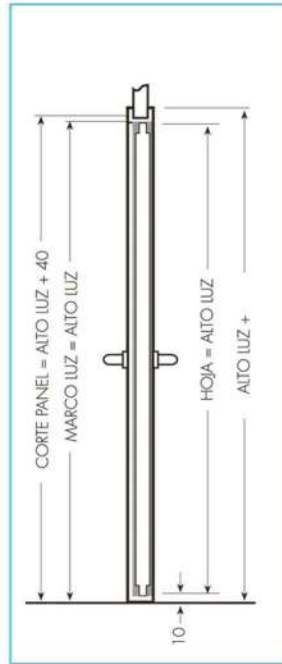
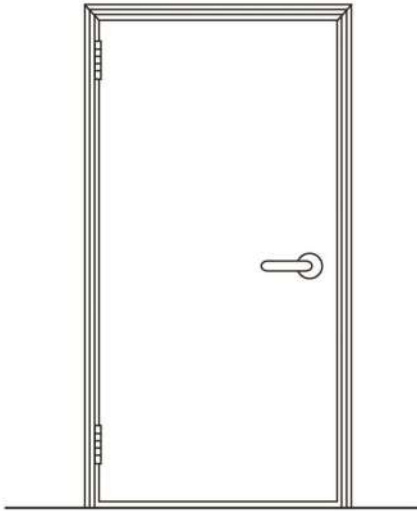

HOJA DOBLE

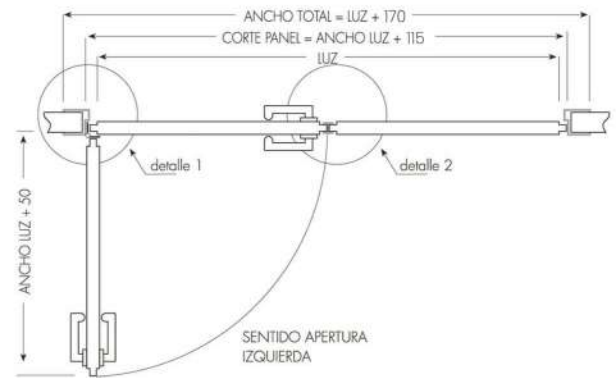
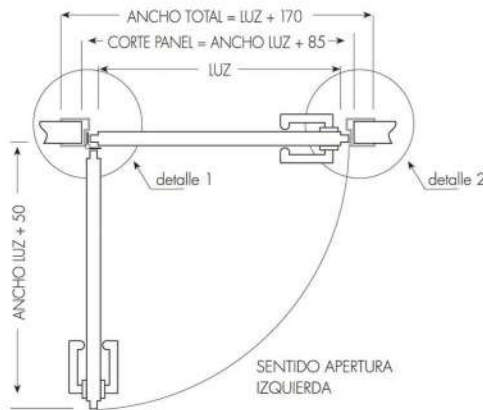
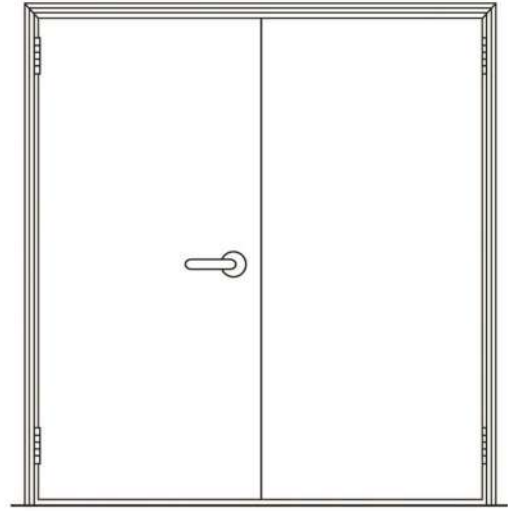

ANCHO LUZ	ALTO LUZ	Nº BISAGRAS
≤ 950	< 2200	2
>950	< 2200	3
≤ 1200	≥ 2200	3
MAX. 1200	MAX. 3000	

ANCHO LUZ	ALTO LUZ	Nº BISAGRAS
≤ 1900	< 2200	4
> 1900	< 2200	6
≤ 2400	≥ 2200	6
MAX. 2400	MAX. 2400	

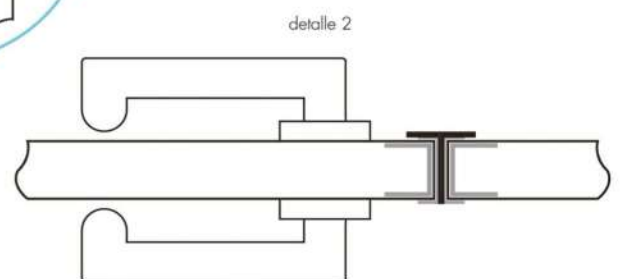
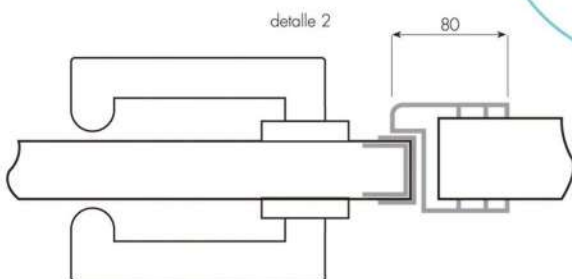
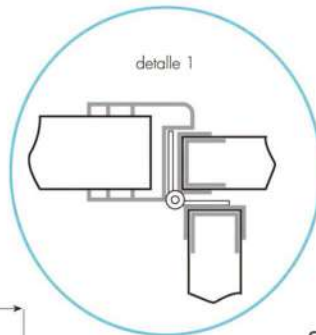

SINGLE LEAF

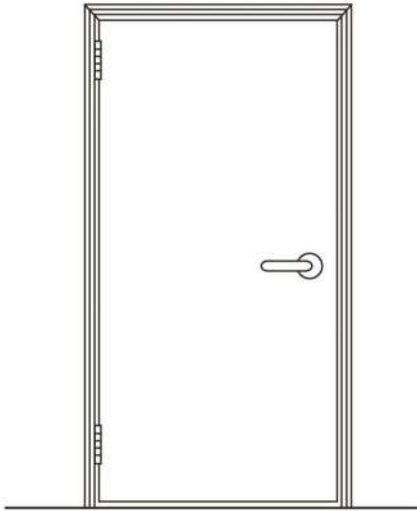

DOUBLE LEAF

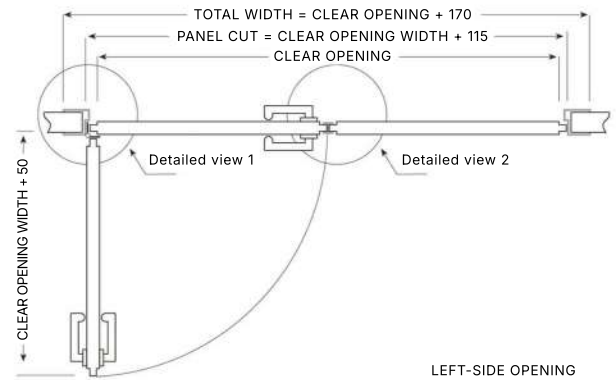
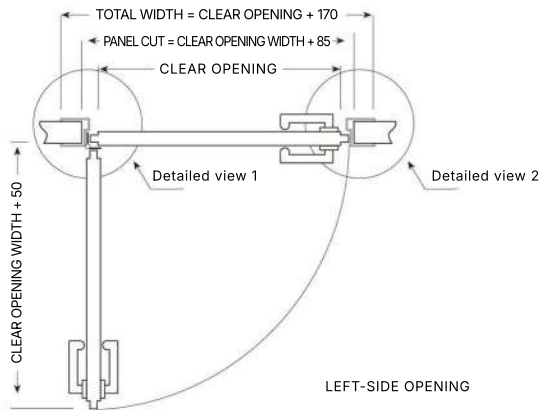
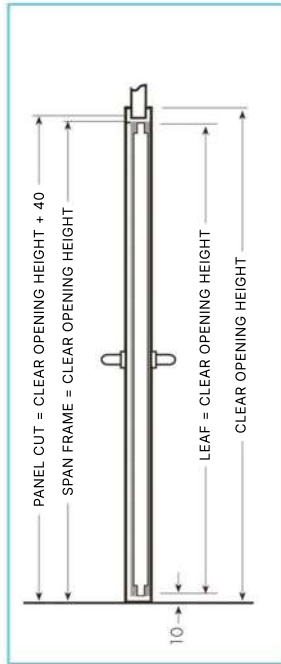
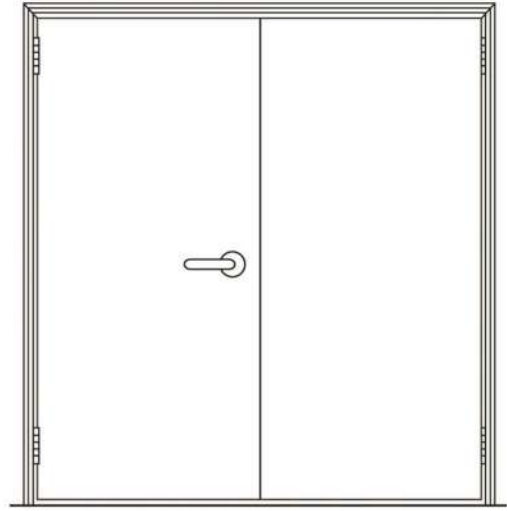

CLEAR OPENING WIDTH	CLEAR OPENING HEIGHT	NO. HINGES
≤ 950	< 2200	2
>950	< 2200	3
≤ 1200	≥ 2200	3
MAX. 1200	MAX. 3000	

CLEAR OPENING WIDTH	CLEAR OPENING HEIGHT	NO. HINGES
≤ 1900	< 2200	4
> 1900	< 2200	6
≤ 2400	≥ 2200	6
MAX. 2400	MAX. 2400	

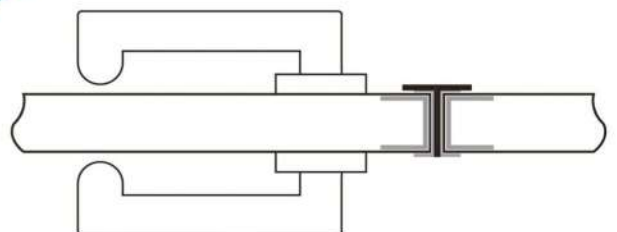
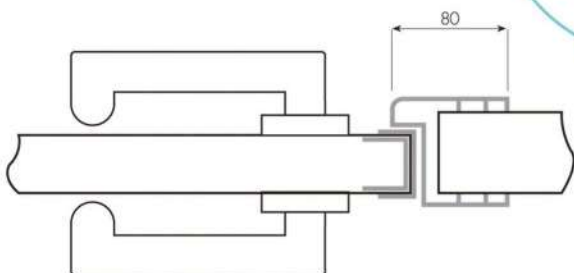
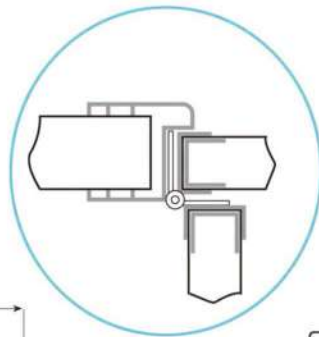

SERVICIO
SERVICE
SERVICE

MOD **N40**
SOBRE MARCO
ON FRAME
SUR CADRE

SIMPLE BATTANT

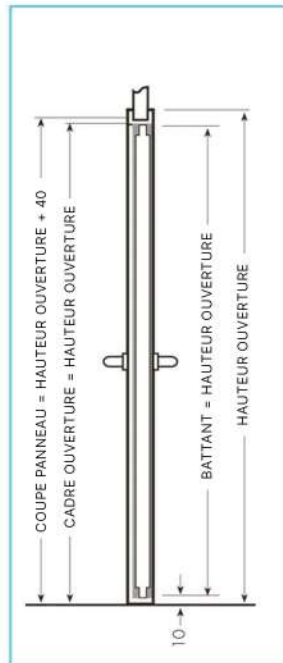
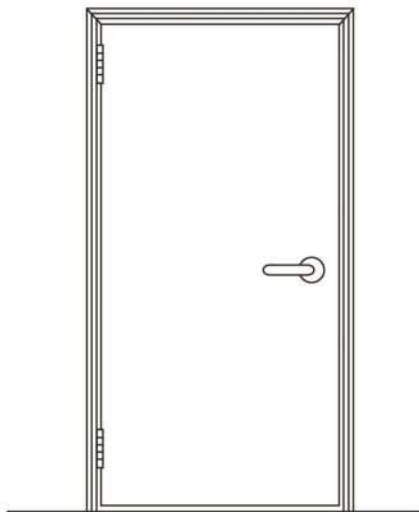

DOUBLE BATTANT

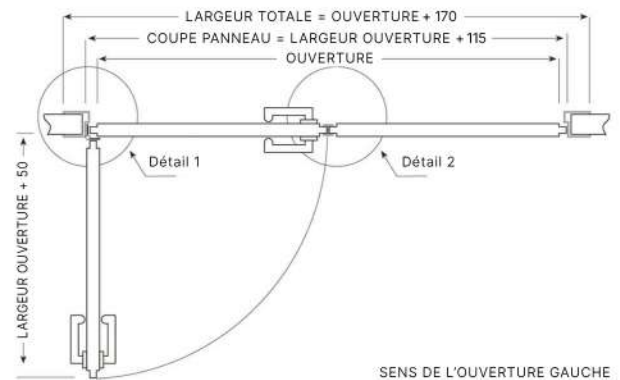
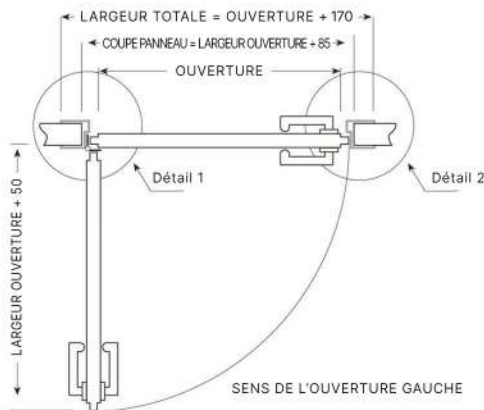
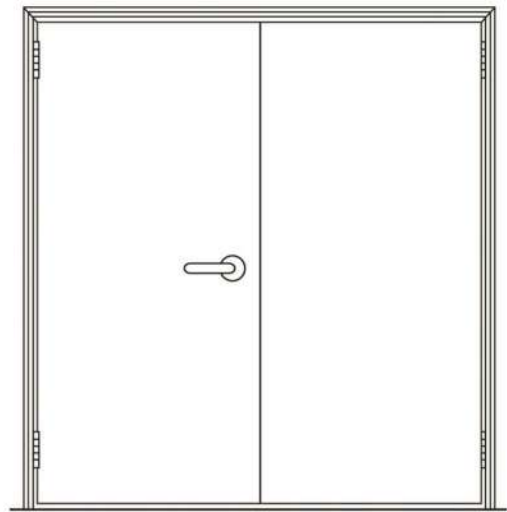

LARGEUR OUVERTURE	LARGEUR OUVERTURE	NBRE. DE CHARNIÈRES
≤ 950	< 2200	2
>950	< 2200	3
≤ 1200	≥ 2200	3
MAX. 1200	MAX. 3000	

LARGEUR OUVERTURE	LARGEUR OUVERTURE	NBRE. DE CHARNIÈRES
≤ 1900	< 2200	4
> 1900	< 2200	6
≤ 2400	≥ 2200	6
MAX. 2400	MAX. 2400	

